

<p><u>All Aboard</u></p> 	<p><u>TIPS</u></p> <ol style="list-style-type: none"> 1. Can the group think of a way to get hold of the first rope from the starting platform (e.g. Hooking it with a tree branch)? 2. Wooden platforms can be moved around to suit group's ability. 3. Be aware of slippery surfaces in wet weather.
<p><u>Travelling Tyre</u></p> 	<p><u>TIPS</u></p> <ol style="list-style-type: none"> 1. Can each person travel across without touching the floor. 2. Can the children think of different ways of getting across on the tyre (e.g. Standing, sitting, lying)? 3. Spotter needed to catch and steady tyre near the trees. 4. Be aware of feet getting caught inside the tyre when climbing up or down.
<p><u>Criss Cross</u></p> 	<p><u>TIPS</u></p> <ol style="list-style-type: none"> 1. Spotters needed at both sides in case of sudden fall. 2. Be aware this can be a strenuous activity, keeping the body as upright as possible can reduce strain on the arms.
<p><u>Balance Walk</u></p> 	<p><u>TIPS</u></p> <ol style="list-style-type: none"> 1. Try walking across without falling off, stand on one leg in the middle, perform a 180-degree etc. 2. If children can't balance on their own, ask them to put their arms out to the side palms down. Touch their palm with one of your fingers as they walk across and they will balance with ease!
<p><u>Postman's Walk</u></p> 	<p><u>TIPS</u></p> <ol style="list-style-type: none"> 1. Can have more than one child on this activity at once, (max. 4 children at any one time) 2. Be aware of suddenly swinging forwards or backwards.

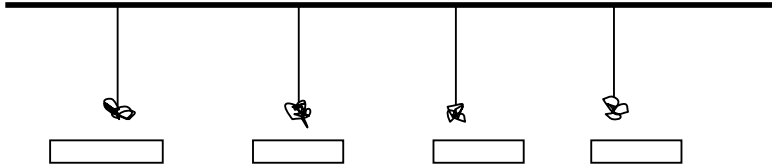

Scramble Net – TIPS

1. Traverse across the net without holding the top of the net or wire and without feet touching the floor.
2. **Do not** climb over the top.
3. Increase difficulty of task by using overhanging side of net.

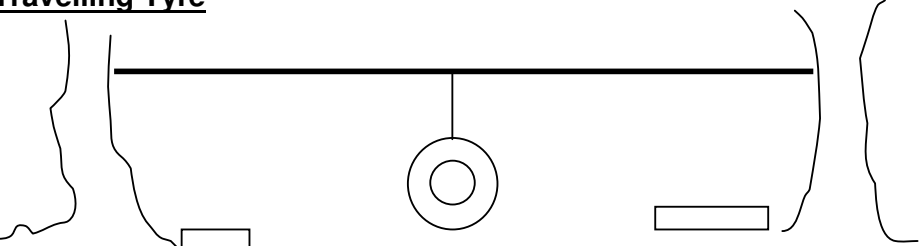
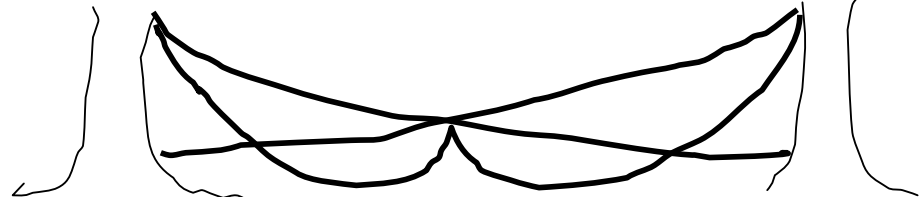
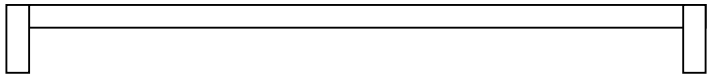
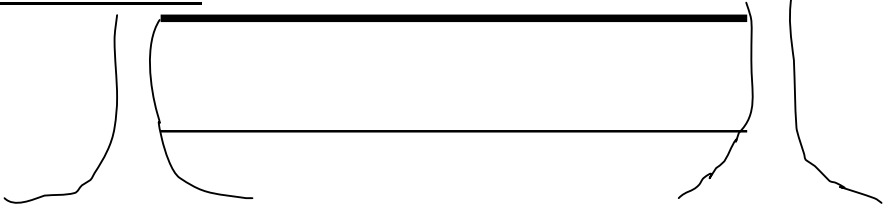
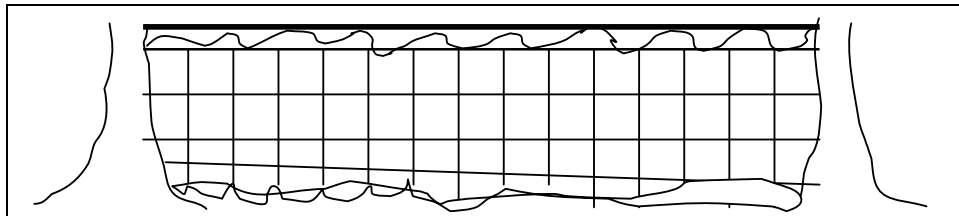
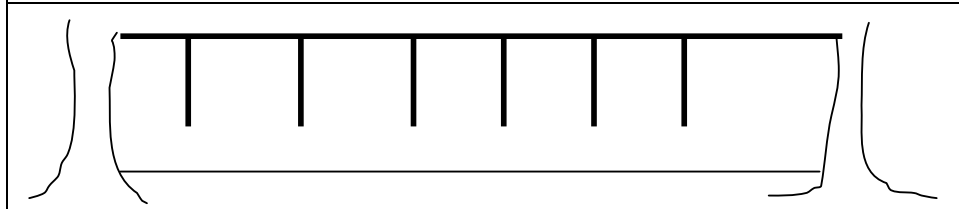

Hanging Vines – TIPS

1. Use the ropes to hold on to and balance across the wire (easier if the ropes are held taut).
2. Can the group find ways of helping one another to get across, e.g. Passing the vines back to the person following.

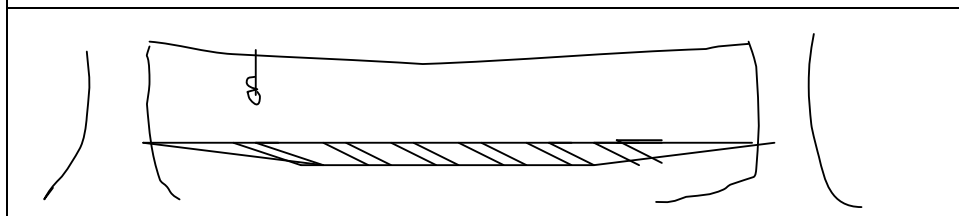

Twitch Ladder– TIPS

1. Find different ways of crossing the ladder without touching the floor.
2. Carry an object across with you.
3. Use the rope overhead if you need help to balance.

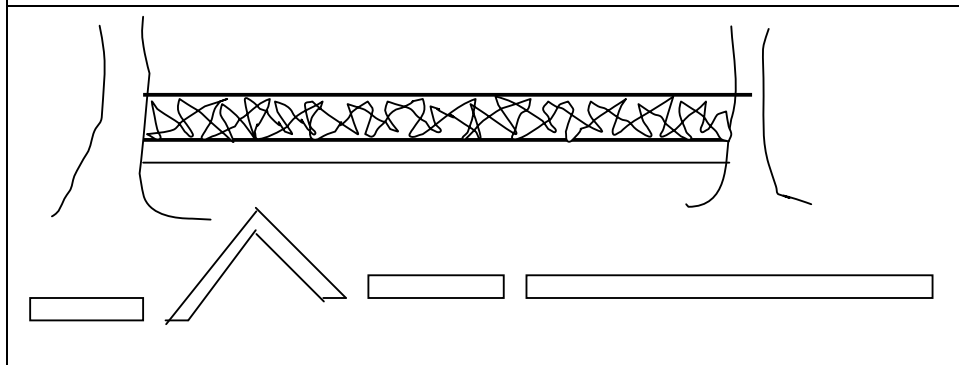

Balance Beam & Stile Walkway – TIPS

1. Using some of the following ideas can slow this section down.
 - a. Get the group on to the fixed beam and play the name, height or age game (the group have to get into order without stepping off the beam).
 - b. Travel along the beam and planks with the group carrying a tray of snooker balls, bucket of water and a plank. Each time one person carries an item they are only allowed to take four steps with it. It is then passed onto someone else (all members of the group have a turn).

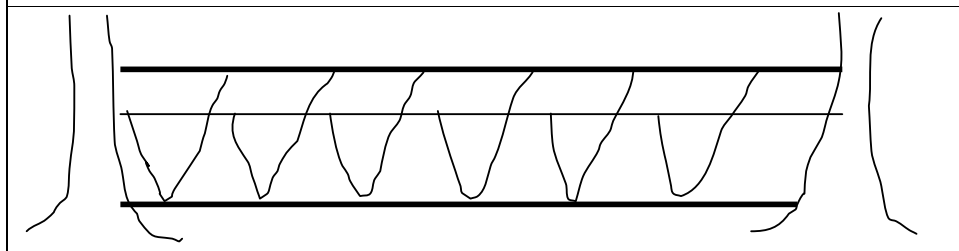

Burma Bridge – TIPS

1. Placing feet in V can provide more security
2. Be aware of height of rope should a member of the group slip and straddle the bottom rope – could be painful!!
3. Possible to have a maximum of 4 people on the bridge.
4. Can continue with the balls, water and plank game across the bridge.

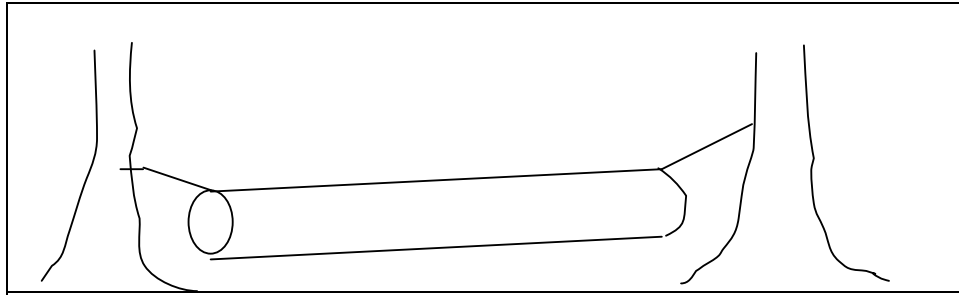

Wobbly Log – TIPS

1. Another balance exercise, which is more difficult to walk across than the fixed beam. Can use finger on palm trick to help balance.
2. Find other ways of travelling across the log e.g. sitting astride, sideways, under. If going sideways, it is possible to fall backwards – need to spot.

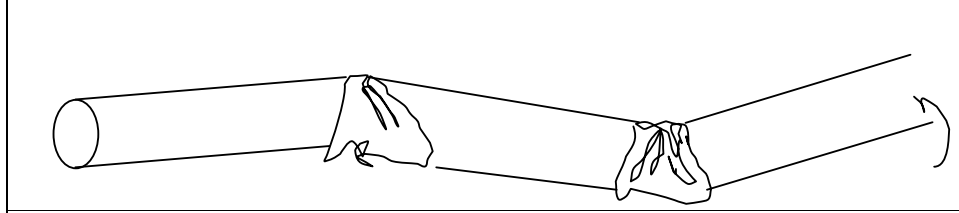

Tunnel – TIPS

1. A low crawl through various sections of large pipe.
2. You can talk to the children on their journey through the tunnel if necessary, by lifting the waterproof covers at the breaks in the pipe. This can also be used as an emergency escape if necessary.

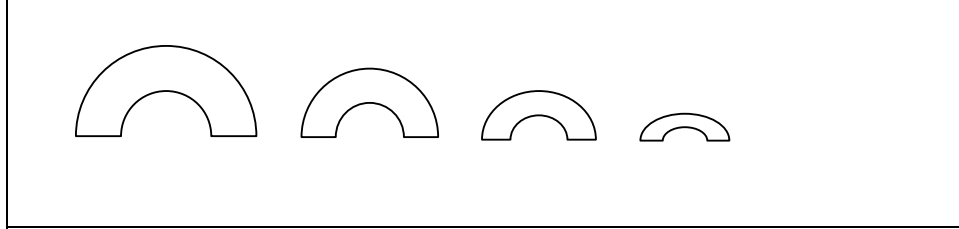

Loch Ness Monster Tyres – TIPS

1. Be aware they may be slippery in the wet.

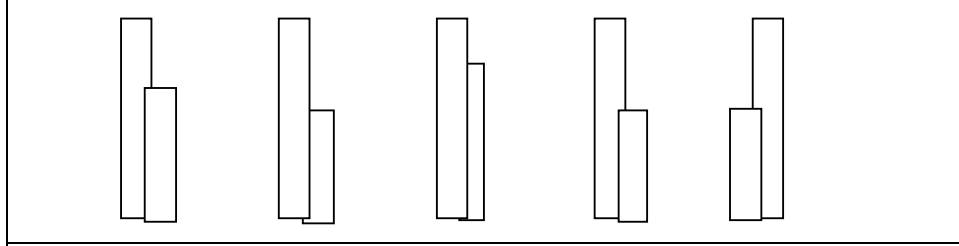

Stilts – TIPS

1. Walk through the poles with hands and feet at different heights.
2. Can you walk backwards?

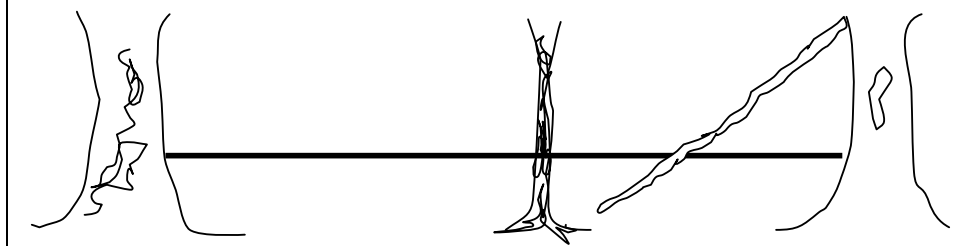

Mohawk Walk – TIPS

1. Have a spotter by the thin tree in front of the cable, so that anyone swinging off won't hit the tree.
2. Spotters are essential in front and behind, especially when children are making a move from the end of the rope to the tree.
3. Beware; the wire may be slippery when wet.

New element to be built here.

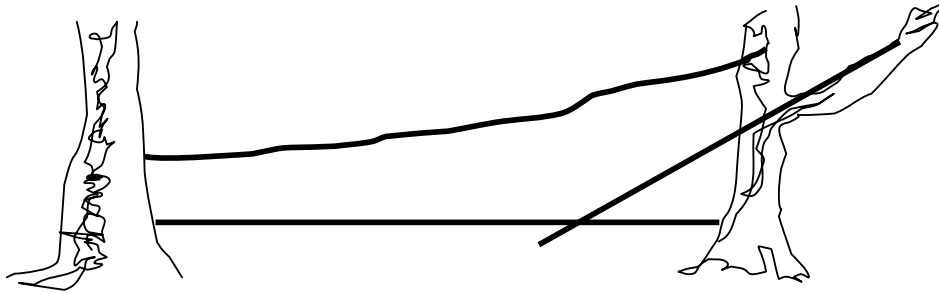

The Wobbly Postman's Walk – TIPS

1. Use the loose rope to help you balance along the wire to reach the wobbly rope overhead.
2. A spotter may be needed behind the person crossing the wire.
3. Can have more than one child on this activity at once, (max. 3 children at any one time).
4. Be aware of suddenly swinging forwards or backwards.
5. This activity becomes more difficult as the rope gets lower.

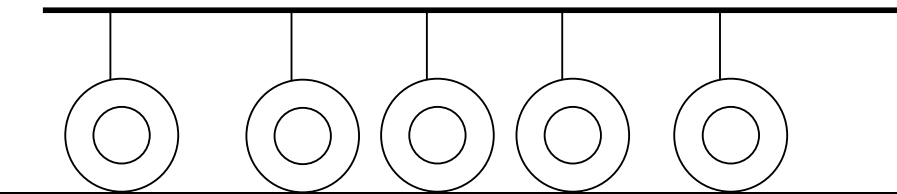

Swinging Tyres - TIPS

1. Move across the tyres without touching the floor.
2. Can the children find different ways of getting across the tyres?
3. Be aware of feet getting caught in the tyres.
4. Spotters not recommended as they may get hit by swinging tyres.

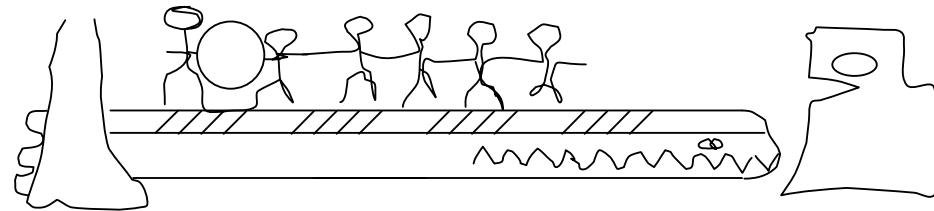

Crocodile Log and Tree stump - TIPS

1. Can the group find different ways of travelling along the log?
2. Can a balance be performed half way along?
3. Stand the group in a line holding hands. Can they pass a hoop down the line without breaking hands?
4. Some group members may need assistance stepping onto the tree stump at the end.

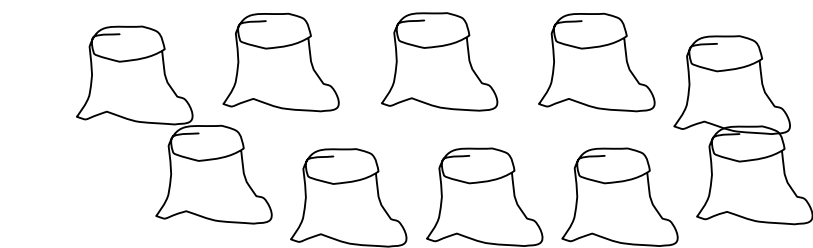

Shelter – TIPS

1. This area can be used as a place to review the activity.
 - a. Likes and dislikes.
 - b. Did the group work well as team when they needed to?
 - c. What could the group improve – communication, support, trust etc.